



JOHN DEERE

6068HF258

POWER TECH

SPECIFICATIONS

For Gen Set Applications

TA LUFT approved @ 1500 rpm

EPA - CARB Tier 1 Certified @ 1800 rpm

Power Units

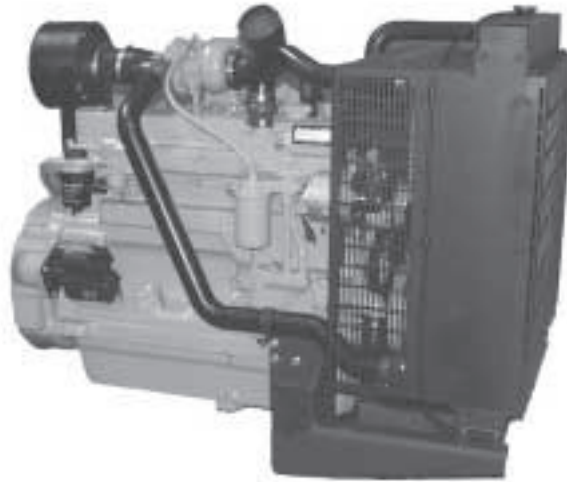

PERFORMANCE DATA

Speed (Hz)	Generator Efficiency %	Fan Power kW	Power Factor	Calculated Gen Set rating					
				Prime			Standby ⁽¹⁾		
				kW net	kVA	kWe	kW net	kVA	kWe
1500 (50)	88-92	6.5	0.8	160	175-183	140-147	177	194-202	155-162
1800 (60)	88-92	10.4	0.8	179	196-205	157-164	200	220-230	176-184

Note⁽¹⁾: based on nominal engine power

STANDBY POWER

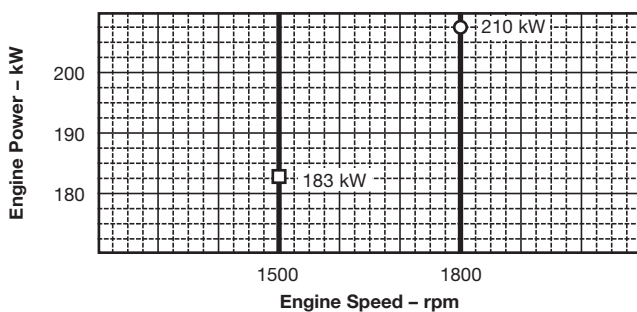

PRIME POWER

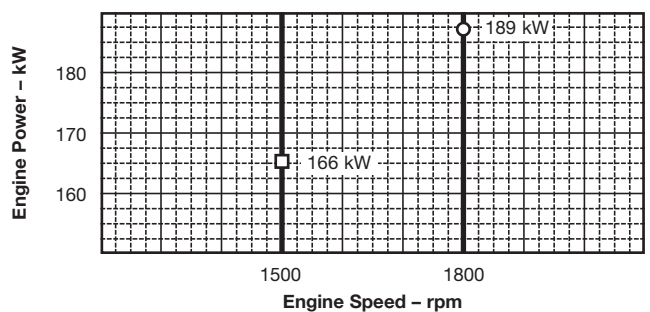

Performance Data

	1500 rpm	1800 rpm
Gross Rated Power (without fan)		
Prime = PRP - kW (hp)	166 (223)	189 (253)
Standby = LTP - kW (hp)	183 (245)	210 (282)
Rated Speed - rpm	1500	1800
Low Idle Speed - rpm	No	No
BMEP		
Prime = PRP - kPa (psi)	1956 (283)	1876 (272)
Standby = LTP - kPa (psi)	2157 (313)	2065 (299)
Friction Power @ Rated Speed - kW (hp)	13 (17)	17 (23)
Altitude Capability		
Prime - m (ft)	2300 (7500)	2300 (7500)
Standby - m (ft)	1500 (5000)	1500 (5000)
Air: Fuel Ratio		
Prime = PRP	21.1 : 1	23.7 : 1
Standby = LTP	20.4 : 1	22.7 : 1
Noise		
Prime = PRP - dB(A) @ 1 m	93.6	95.5
Standby = LTP - dB(A) @ 1 m	94.9	96.9

STANDBY POWER is the nominal engine power available at varying load factors for up to 500 hours per year. This rating conforms to ISO 8528-1 "limited time running power (LTP)". The calculated generator set rating range for standby applications is based on minimum engine power (nominal -5%) to provide 100% meet-or-exceed performance for assembled standby generator sets.

PRIME POWER is the nominal power an engine is capable of delivering with a variable load for an unlimited number of hours per year. This rating conforms to ISO 8528-1 "prime power (PRP)".

Photograph may show non standard equipment.



Power Unit Specification Data

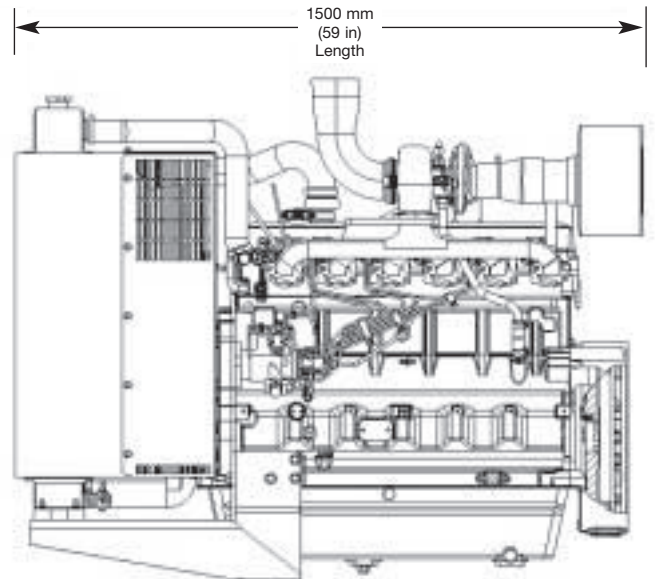
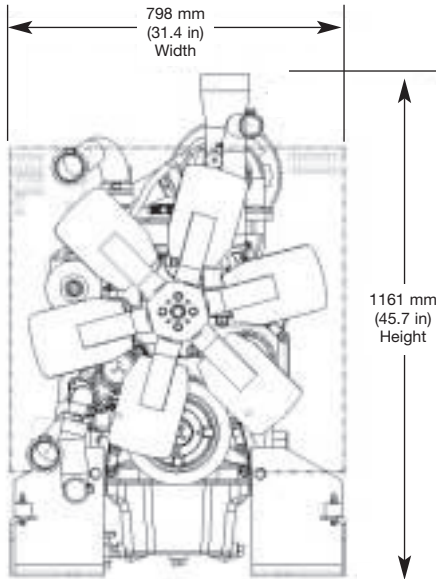

Fuel Consumption – l/h	1500 rpm		1800 rpm	
	Prime = PRP	Standby = LTP	Prime = PRP	Standby = LTP
25% Power	10.7	11.5	12.6	13.5
50% Power	20.5	22.1	23.5	25.9
75% Power	31.3	34.4	36.1	39.9
100% Power	40.8	45.2	47.2	51.9

Rated power guaranteed within + or – 5% at SAE J1995 and ISO 3046

General Data

Model	6068HF258
Number of cylinders	6
Bore and Stroke – mm (in.)	106 x 127 (4.19 x 5.00)
Displacement – dm ³ (in ³)	6.8 (414)
Compression Ratio	17.0 : 1
Valves per Cylinder – Intake/Exhaust	1 / 1
Firing Order	1-5-3-6-2-4
Combustion System	Direct Injection
Engine type	In-line, 4-cycle
Aspiration	Turbocharged
Charge Air Cooling System	Air to air
Engine Crankcase Vent System	Open
Engine Crankcase Pressure – kPa (in.H ₂ O)	0.5 (2)

Physical Data

Length – mm (in.)	1500 (59)
Width – mm (in.)	798 (31.4)
Height – mm (in.)	1161 (45.7)
Weight, dry – kg (lb)	764 (1684)
(Includes flywheel housing, flywheel, & electrics)	
Center of gravity location	
From Rear Face of block (X-axis) – mm (in.)	450 (17.7)
Right of Crankshaft (Y-axis) – mm (in.)	-10 (-0.4)
Above Crankshaft (Z-axis) – mm (in.)	176 (6.9)

Electrical Data

Recommended Battery Capacity (CCA)	
12 Volt System – Amp	800
24 Volt System – Amp	570
Maximum Allowable Starting Circuit Resistance	
12 Volt System – Ohm	0.0012
24 Volt System – Ohm	0.002
Starter Rolling Current – 12 Volt System	
At 0°C (32°F) – Amp	920
At -30°C (-22°F) – Amp	1300
Starter Rolling Current – 24 Volt System	
At 0°C (32°F) – Amp	600
At -30°C (-22°F) – Amp	700

Specifications and design subject to change without notice.

Air System

	1500 rpm	1800 rpm
Maximum Allowable Temperature Rise		
Ambient Air to Engine Inlet – °C (°F)	8 (15)	8 (15)
Maximum Air Intake Restriction		
Dirty Air Cleaner – kPa (in. H ₂ O)	6.25 (25)	6.25 (25)
Clean Air Cleaner – kPa (in. H ₂ O)	3 (12)	3 (12)
Engine Air Flow		
Prime = PRP – m ³ /min (ft ³ /min)	10.7 (378)	13.9 (491)
Standby = LTP – m ³ /min (ft ³ /min)	11.5 (406)	14.8 (523)

Exhaust System

	1500 rpm	1800 rpm
Exhaust Flow		
Prime = PRP – m ³ /min (ft ³ /min)	30.3 (1070)	37.5 (1324)
Standby = LTP – m ³ /min (ft ³ /min)	32.9 (1162)	40.3 (1423)
Exhaust Temperature		
Prime = PRP – °C (°F)	590 (1094)	551 (1024)
Standby = LTP – °C (°F)	603 (1117)	567 (1053)
Max. Allow. Back Pressure – kPa (in.H ₂ O)	7.5 (30)	7.5 (30)
Recommended Exhaust Pipe Dia – mm (in.)	101.6 (4)	101.6 (4)

Cooling System

	1500 rpm	1800 rpm
Thermostat Start to open – °C (°F)	82 (180)	82 (180)
Power Unit Coolant Capacity – L (qt)	27.0 (28.5)	27.0 (28.5)
Minimum Air to Boil temperature – °C (°F)	47 (117)	47 (117)

Fuel System

	1500 rpm	1800 rpm
Fuel Injection Pump	Stanadyne	Stanadyne
Governor Regulation	5%	5%
Governor Type	Mechanical	Mechanical
Total Fuel Flow		
Prime = PRP – kg/h (lb/h)	93 (205)	96 (212)
Standby = LTP – kg/h (lb/h)	93 (205)	96 (212)
Maximum Fuel Transfer Pump Suction – m (ft)	0.9 (3)	0.9 (3)
Fuel Filter Micron Size @ 98% Efficiency	8	8

Lubrication System

	1500 rpm	1800 rpm
Oil Pressure at Rated Speed – kPa (psi)	345 (50)	345 (50)
Oil Pressure at Low Idle – kPa (psi)	105 (15)	105 (15)
In Pan Oil Temperature – °C (°F)	125 (257)	125 (257)
Total Engine Oil Capacity with filter – L (qt)	32 (34)	32 (34)
Engine Angularity Limits (continuous)		
Any Direction – degrees	20	20