



JOHN DEERE

4045TF158

POWER TECH

SPECIFICATIONS

For Gen Set Applications

TA LUFT approved @ 1500 rpm

EPA - CARB Tier 1 Certified @ 1800 rpm

Power Units

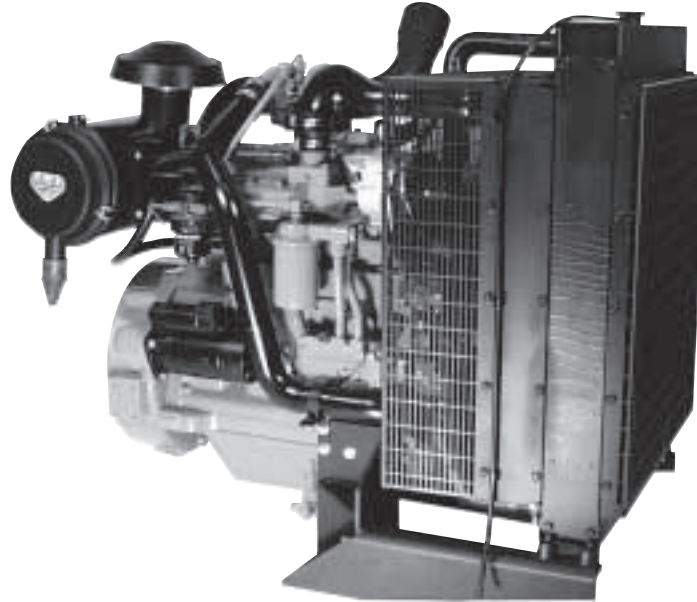

PERFORMANCE DATA

Speed (Hz)	Generator Efficiency %	Fan Power kW	Power Factor	Calculated Gen Set rating					
				Prime			Standby		
				kW net	kVA	kWe	kW net	kVA	kWe
1500 (50)	88-92	3.5	0.8	88	97-101	77-81	96.5	106-111	85.89
1800 (60)	88-92	4	0.8	108	118-124	95-100	119	130-136	104-109

STANDBY POWER

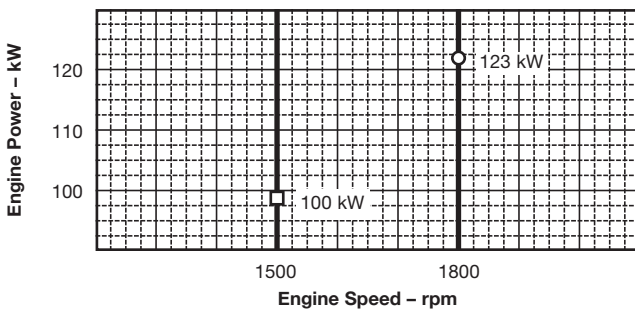

PRIME POWER

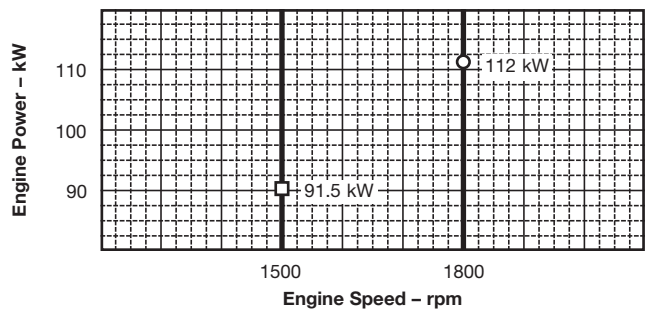

Performance Data

	1500 rpm	1800 rpm
Gross Rated Power (without fan)		
Prime = PRP - kW (hp)	91 (122)	112 (150)
Standby = LTP - kW (hp)	100 (134)	123 (165)
Rated Speed - rpm	1500	1800
Low Idle Speed - rpm	No	No
BMEP		
Prime = PRP - kPa (psi)	1626 (236)	1659 (240)
Standby = LTP - kPa (psi)	1778 (258)	1822 (264)
Friction Power @ Rated Speed - kW (hp)	10 (13)	13 (17)
Altitude Capability		
Prime - m (ft)	2300 (7500)	2300 (7500)
Standby - m (ft)	1500 (5000)	1500 (5000)
Air: Fuel Ratio		
Prime = PRP	25.3 : 1	30.3 : 1
Standby = LTP	25.4 : 1	30.3 : 1
Noise		
Prime = PRP - dB(A) @ 1 m	93.9	94.1
Standby = LTP - dB(A) @ 1 m	94.5	95.4

STANDBY POWER is the nominal engine power available at varying load factors for up to 500 hours per year. This rating conforms to ISO 8528-1 "limited time running power (LTP)". The calculated generator set rating range for standby applications is based on minimum engine power (nominal -5%) to provide 100% meet-or-exceed performance for assembled standby generator sets.

PRIME POWER is the nominal power an engine is capable of delivering with a variable load for an unlimited number of hours per year. This rating conforms to ISO 8528-1 "prime power (PRP)".

Photographs may show non standard equipment.



Power Unit Specification Data

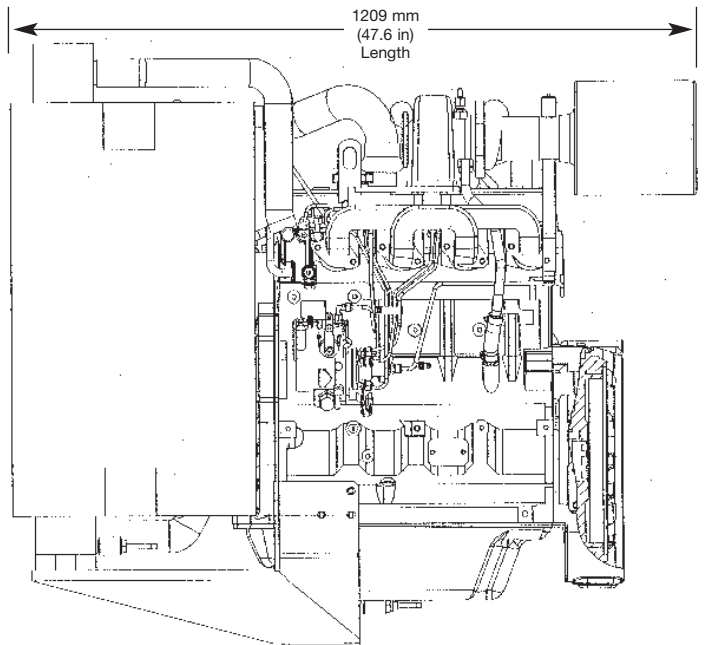
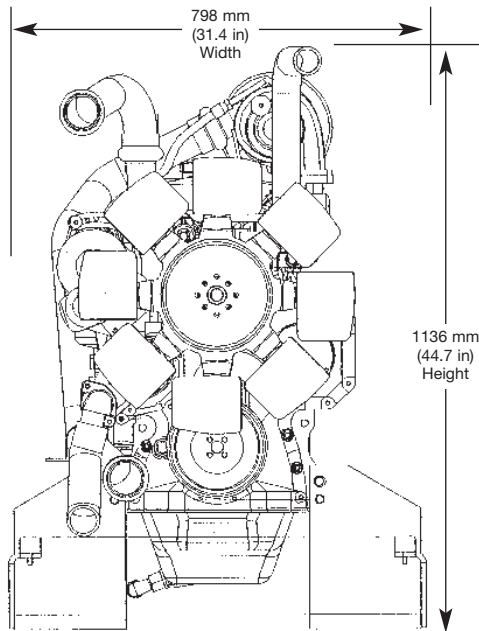

Fuel Consumption – l/h	1500 rpm		1800 rpm	
	Prime = PRP	Standby = LTP	Prime = PRP	Standby = LTP
25% Power	6.0	6.5	7.5	8.5
50% Power	11.0	12.0	13.5	15.0
75% Power	16.5	18.5	21.0	23.0
100% Power	23.0	25.0	27.5	30.5

General Data

Model	4045HF158
Number of cylinders	4
Bore and Stroke – mm (in.)	106 x 127 (4.19 x 5.00)
Displacement – dm ³ (in ³)	4.5 (276)
Compression Ratio	17.0 : 1
Valves per Cylinder – Intake/Exhaust	1 / 1
Firing Order	1-3-4-2
Combustion System	Direct Injection
Engine type	In-line, 4-cycle
Aspiration	Turbocharged
Charge Air Cooling System	Air to air
Engine Crankcase Vent System	Open
Engine Crankcase Pressure – kPa (in.H ₂ O)	0.5 (2)

Physical Data

Length – mm (in.)	1209 (47.6)
Width – mm (in.)	798 (31.4)
Height – mm (in.)	1136 (44.7)
Weight, dry – kg (lb)	605 (1334)
(Includes flywheel housing, flywheel, & electrics)	
Center of gravity location	
From Rear Face of block (X-axis) – mm (in.)	285 (11.2)
Right of Crankshaft (Y-axis) – mm (in.)	-10 (-0.4)
Above Crankshaft (Z-axis) – mm (in.)	151 (5.9)

Electrical Data

Recommended Battery Capacity (CCA)	
12 Volt System – Amp	640
24 Volt System – Amp	570
Maximum Allowable Starting Circuit Resistance	
12 Volt System – Ohm	0.0012
24 Volt System – Ohm	0.002
Starter Rolling Current – 12 Volt System	
At 0°C (32°F) – Amp	780
At -30°C (-22°F) – Amp	1000
Starter Rolling Current – 24 Volt System	
At 0°C (32°F) – Amp	600
At -30°C (-22°F) – Amp	700

Specifications and design subject to change without notice.

Air System

	1500 rpm	1800 rpm
Maximum Allowable Temperature Rise		
Ambient Air to Engine Inlet – °C (°F)	8 (15)	8 (15)
Maximum Air Intake Restriction		
Dirty Air Cleaner – kPa (in. H ₂ O)	6.25 (25)	6.25 (25)
Clean Air Cleaner – kPa (in. H ₂ O)	3 (12)	3 (12)
Engine Air Flow		
Prime = PRP – m ³ /min (ft ³ /min)	6.4 (226)	9.1 (321)
Standby = LTP – m ³ /min (ft ³ /min)	7.0 (247)	10.0 (353)

Exhaust System

	1500 rpm	1800 rpm
Exhaust Flow		
Prime = PRP – m ³ /min (ft ³ /min)	17.0 (600)	24.0 (847)
Standby = LTP – m ³ /min (ft ³ /min)	18.7 (660)	26.4 (932)
Exhaust Temperature		
Prime = PRP – °C (°F)	545 (1013)	490 (914)
Standby = LTP – °C (°F)	565 (1049)	475 (887)
Max. Allow. Back Pressure – kPa (in.H ₂ O)	7.5 (30)	7.5 (30)
Recommended Exhaust Pipe Dia – mm (in.)	101.6 (4)	101.6 (4)

Cooling System

	1500 rpm	1800 rpm
Thermostat Start to open – °C (°F)	82 (180)	82 (180)
Power Unit Coolant Capacity – L (qt)	25.0 (26.5)	25.0 (26.5)
Minimum Air to Boil temperature – °C (°F)	47 (117)	47 (117)

Fuel System

	1500 rpm	1800 rpm
Fuel Injection Pump	Stanadyne	Stanadyne
Governor Regulation	5%	5%
Governor Type	Mechanical	Mechanical
Total Fuel Flow		
Prime = PRP – kg/h (lb/h)	93 (205)	96 (212)
Standby = LTP – kg/h (lb/h)	93 (205)	96 (212)
Maximum Fuel Transfer Pump Suction – m (ft)	0.9 (3)	0.9 (3)
Fuel Filter Micron Size @ 98% Efficiency	8	8

Lubrication System

	1500 rpm	1800 rpm
Oil Pressure at Rated Speed – kPa (psi)	345 (50)	345 (50)
Oil Pressure at Low Idle – kPa (psi)	105 (15)	105 (15)
In Pan Oil Temperature – °C (°F)	115 (240)	115 (240)
Total Engine Oil Capacity with filter – L (qt)	12 (12.7)	12 (12.7)
Engine Angularity Limits (continuous)		
Any Direction – degrees	20	20